

Response to Welsh Affairs Committee- Inquiry into Ports in Wales

Introduction

I am Jim O'Toole, Managing Director of The Port of Mostyn Ltd in Flintshire. I am a Deputy Lieutenant to the Clwyd Lieutenancy and a past Chairman of the North Wales CBI which I represented on the North Wales Economic Forum. I am also a member of the Bank of England Advisory Panel for North Wales, and also represent Welsh ports and industrial interests on the Dee estuary relating to the Water Framework Directive. I have more than 50 years experience in the shipping and ports industries.

Regulatory Regime

Ports is a reserved matter and current U.K. policy is contained in the document "*Modern Ports*" – a U.K. Policy – Nov. 2000. The Welsh Assembly Government 's parallel policies on ports are contained mainly in two policy documents: "*The Wales Freight Strategy*" - May 2008 and "*Wales Transport Strategy*" - April 2008. Neither of the Welsh documents contain what could be regarded as firm policies for Welsh port development, indeed the Transport Strategy document makes no more than a passing reference to ports and sea transport.

The Wales Freight Strategy document provides an overview of the Welsh ports sector and contains 10 policy statements. However, scrutiny of the policy statements shows they are little more than intentions to "continue to review" and to "continue to monitor" various strategies for potential port development.

I am therefore not convinced that the Welsh Assembly Government fully appreciates the importance of ports to the Welsh economy, hence its lack of firm policies which the industry can rely upon when considering development plans.

The necessary regulatory consents which all U.K. ports must obtain in order to carry out both capital and maintenance works in their harbours and navigational channels are usually a *Section 34 Consent under the Coast Protection Act 1949 (CPA)* to carry out the dredging works, and a consent under the *Food and Environmental Protection Act 1985 (FEPA)* for the disposal of the material being dredged.

In some cases, such as at Mostyn, a further consent, being a *Land Drainage Consent* to disturb the riverbed must also be obtained from the Environment Agency (Wales) (EAW) under the *Water Resources Act 1991*. Moreover, in addition to these consents, an "*Assent*" from the Countryside Council for Wales (CCW) under the *Countryside Rights of Way Act 2000* to carry out works within the harbour is also required.

About 70% of the U.K's ports are located on estuaries, which invariably are subject to one or more conservation designations under the E.U. *Habitats* and/or *Birds Directives*. The interpretation of these Directives by the U.K. Regulators is seen by the ports sector as very restrictive when compared against the interpretation used by our European competitors.

For example, in other E.U. countries, harbour areas and navigational channels are generally excluded from conservation designation, whereas in the U.K. they are totally included, resulting in a direct conflict between industry and nature conservation which makes it considerably more onerous, time consuming and expensive to obtain the necessary consents for our ports to develop.

It is often said that when Directives arrive in Westminster from Brussels they are then gold plated by the U.K. Regulators. I would add that when they arrive in Cardiff the Assembly gives them a coat of platinum for good measure, making Wales the most difficult country within the E.U. to obtain consents to develop and operate a port. Surely this must ultimately be to the detriment of the Welsh economy.

To complicate matters, the processing of applications under FEPA is currently undertaken by the *Marine and Fisheries Agency (MFA)* in London on behalf of the Assembly. Moreover, the scientific and technical expertise required to assess Environmental Impact Statements which dredging and disposal consent applications inevitably require, is not readily available in Wales and this work is therefore usually carried out by the *Centre for Environment, Fisheries & Aquatic Science (CEFAS)* based in Lowestoft.

In my experience, there is a reasonable degree of co-operation between the numerous regulatory organizations involved in dealing with consents. However, the extended administrative chain inevitably results in more time and resources being demanded not just of the Regulators, but also of the applicants in order to process consents for channel and harbour works at Welsh ports.

Whereas the present arrangements make life difficult enough for ports to gain consents to undertake essential works, the situation in the near future is likely to be even more complicated and more onerous for the following two reasons:

The first reason being that in addition to the existing legislation under which ports are presently regulated, two new pieces of legislation are approaching the Statute Books. These are the *E.U. Water Framework Directive* which is currently at a public consultation stage, and the *Marine and Coastal Access Bill, (Marine Bill)* which is due to come into force later this year.

When in force, these two additional pieces of legislation will add greatly to the onerous regulatory burden already on ports, and at a time when major changes are taking place in the structure of the regulatory bodies concerned.

This leads directly into the second reason why I believe the regulatory regime may become more onerous and complicated. In 2007 the Welsh Assembly Government established its own *Marine Consents Unit (MCU)* based in Cardiff, which at some time in the future will process applications from Welsh ports under the provisions of the *Marine Bill*, including *CPA* and *FEPA* consents.

Moreover, prior to the transfer to Cardiff, consents currently processed by the MFA in London will be transferred to Newcastle upon Tyne into the new *Marine Management Organization (MMO)* to be formed later this year. It would have been sensible if the transfer of these functions directly from London to Cardiff had been arranged thus avoiding the short term diversion to Newcastle.

Furthermore, historically there has been a high turn-over of MFA staff in London with responsibility for processing consent applications. The major administrative changes soon to take place will likely lead to a loss of those experienced staff due to their unwillingness to re-locate to Newcastle.

This will be at a time when applications for marine works consents throughout the U.K. is expected to be exceptionally high due to the additional demands resulting from the emerging offshore windfarm industry.

Indeed there is anecdotal evidence that ports are already pre-empting a slowing down of application processing in anticipation that these changes will cause a log-jam and delays within an already ponderous system.

From a ports industry standpoint, it is important that due recognition is given by both the Westminster and the Welsh Assembly Governments to the impact this introduction of additional Legislation coupled with the changes to the administration will have on the consents regime.

Whereas it is acknowledged there is now considerable pressure on the public purse, both Governments should endeavour to make available sufficient time and resources and to ensure the transfer of responsibilities for marine consents is not detrimental to the ports industry.

It may be argued that the introduction of the *Infrastructure Planning Commission (IPC)* due to come into being later this year will help alleviate this situation, as it will have powers to determine all of the necessary consents required for marine works over a certain threshold, which in itself is a very welcome move insofar as it goes.

However, the *IPC* can only determine marine works applications for projects over a very high threshold, namely projects related to container terminals with a minimum throughput of 500,000 containers per annum, liquid and general cargo handling facilities with a minimum annual throughput of 5 million tonnes, or a power generation project exceeding 50 Mw for land based generation or 100 Mw for offshore power generation.

With the possible exception of Milford Haven where high volume liquid cargo projects are possible, bulk/general cargo handling developments at Welsh ports are likely to be significantly below the threshold to qualify for determination by the *IPC*.

It therefore seems that the majority of Welsh ports will have to continue operating under the present cumbersome processing system in the hope the situation does not deteriorate while the administrative changes take place and the additional legislation is introduced.

In considering the regulatory restrictions and administrative burdens imposed on the U.K's ports relative to ports in Europe, which are generally state owned, it should be recognised that the majority of U.K's ports, including those in Wales, are now owned by foreign companies with considerable ports and shipping interests elsewhere.

Unless consents to develop and operate the U.K's ports are processed in a timely and efficient manner, it is not unreasonable to expect that future investment will be redirected to those countries which are regarded as more understanding and accommodating towards the ports sector.

Port Development Opportunities

There is little disagreement of the importance of ports to local and regional economies. Historically ports have developed in support of local industries such as coal exports, steelmaking, agriculture and ferry terminals. In the case of The Port of Mostyn, these traditional businesses have all but disappeared, and its survival has only been possible by the decision a few years ago to diversify into construction and service base facilities for the offshore renewable energy sector.

It is Government policy to erect 7,000 wind turbines off the coast of the U.K. over the next ten years. In order to achieve this target, considerable investment will have to be made in port infrastructure.

Success will only be achieved if it is recognised by both the port operators and Government bodies that this industry requires bespoke harbour infrastructure and very considerable areas of port land adjacent to quays. This will not happen if port development plans continue to be impeded by a fragmented and ponderous regulatory system.

Unlike some of its contemporaries, Mostyn has not heeded the Siren promise that untold riches will come the way of the port operator who provides cruise lines with very expensive turn-around port passenger terminals. This lack of belief stems from the fact that Wales simply does not have the catchment area and mass of population to support turn-around cruise operations other than for the smallest ships, which are also small in number.

Furthermore, the costs of providing sophisticated baggage handling and security screening equipment together with experienced personnel for a few odd days business per season is proportionally prohibitive. Whereas turn-around calls may provide a little income to a few supporting service providers such as coach operators, this business is best left to the larger ports with established passenger terminals and good inland transport connections to attract sufficient passenger numbers.

I do believe however that there is a limited amount of business to be had from transit calls, always providing they can be accommodated using existing cargo berths and quayside facilities. Many of the cruise calls made at regional ports are “culture cruises” which originate from other U.K. ports such as Southampton, Tilbury or Harwich.

The majority of passengers who take this type of cruise are usually from the upper quartile of the age profile who do not like to travel by aircraft. Whereas this sector of the cruise market provides some revenue for the port, (typically about £20k from a 1,000 passenger ship) very little of this filters through to the local economy. This is because most passengers will be whisked away from the ship by coach to the particular cultural location, (stately home/garden) and returned to the ship without visiting the port’s local town or city.

Regarding the potential for container terminal development in Wales, the relatively low volume annual throughput of import and export container traffic is not sufficient to support a major investment in a Welsh port. Furthermore, the proposed new Panamax facility for Portbury (Bristol) and a similar project on the River Mersey will serve the future needs of businesses in both north and south Wales respectively. Trade routes which are not served from either of these ports can adequately be provided by feeder services from Southampton, Felixstowe or Continental ports into existing coastal vessel sized terminals.

Whereas this may mean additional inland transport costs for Welsh businesses, to some extent these costs would be offset against the higher charges an under-utilised global shipping sized Welsh container terminal would need to charge to maintain viability. It is therefore unlikely that a large Welsh terminal to handle global container shipping would be commercially viable in the foreseeable future.

I cannot comment on policing and security at other Welsh ports. However, the combined H.M. Customs and Revenue, Immigration and Port Security establishment at Mostyn works well and is not unduly intrusive into the Port’s business.

SUMMARY

Regulatory Regime

The U.K. and Welsh ports policies are not sufficiently robust to give developers guidance and confidence when considering potential investments.

The existing regulatory system for obtaining the necessary consents for the development and operation of ports is fragmented and ponderous. This situation is likely to be exacerbated in the coming months by organizational changes and additional legislation.

With the decline of manufacturing in Wales, alternative business for ports must be secured. The emerging offshore renewable energy sector presents a good opportunity but this will require port projects to be consented and constructed in a timely manner. Failure to do so may result in investment being made outside the U.K.

Port Development Opportunities

Opportunities to develop large scale bulk and conventional cargo handling facilities in Wales is likely to be confined to bulk liquid handling.

Cruise Market Opportunities

The development in Welsh ports of dedicated cruise terminals as turn-around ports is hampered due to insufficient passenger numbers and geographic location. Opportunities for cruise ship transit calls can developed but the economic benefit these will bring to the port and local economy will be limited.

Container Terminal Opportunities

Similar to the bulk cargo handling sector, declining industrial and manufacturing activity makes container terminals in Wales unnecessary. Global container services can be operated using Portbury and Mersey facilities alongside feeder services from major U.K. and Continental ports.

Policing and port Security

My knowledge of other Welsh ports on this matter is limited. However from my experience at Mostyn, policing and security measures in place are not unduly intrusive.

RECOMMENDATIONS

Welsh ports policies are reviewed and strengthened to give confidence to port operators considering investment proposals.

Measures are put in place to ensure the pending administrative changes and additional legislation does not result in the processing of consents becoming more onerous.

A review of the effects the application of the Habitats and Birds directives is having on port development to be carried out with the purpose of achieving a more equitable balance between the requirements of industry and conservation interests.

Government encouragement should be given to the development of small scale container terminals.

THE
PORT of MOSTYN
LIMITED



Presentation to Flintshire Renewables Event

BRIEF HISTORY

Mostyn is one of the oldest of the UK's commercial ports with a history dating back to the early 16th century.

- @ Privately and independently owned and operated port;**
- @ Statutory Harbour Authority;**
- @ Competent Authority for Pilotage**

Pre development of the port's deepwater berths (2001); cargoes were those typically handled at smaller regional ports:

- Steel
- Timber
- Animal feedstuffs
- Fertilizers
- Aggregates





In 2004 diversified into handling aircraft components, primarily wings for the Airbus A380 aircraft (Super-Jumbo)



Offshore Windfarms constructed from Mostyn since 2004 and new projects scheduled over the next five years:

- **North Hoyle** (*North Wales Coast*)
- **Burbo Bank** (*River Mersey*)
- **Robin Rigg** (*Solway Firth*)
- **Rhyl Flats** (*North Wales Coast*)
- **Walney 1** (*offshore of Barrow-in-Furness*)
- **Walney 2** (*offshore of Barrow-in-Furness*) [completes 2011]
- **Gwynt-y-Mor** (*Liverpool Bay*) [commences 2012]

















Some of the offshore construction vessels which have operated from Mostyn



Seajacks Kraken, Goliath & Vagant



Mayflower Resolution



LISA-A

Typical Service Boats



Major stages of Offshore Windfarm construction:

- ◆ Installation of foundations;
- ◆ Installation of Transition Pieces;
- ◆ Erection of Turbine Towers;
- ◆ Positioning of the Nacelle (the turbine);
- ◆ Connecting of blades;
- ◆ Laying and connection of inter-ray cable between the individual turbines;
- ◆ Laying of main cables to offshore substations/onshore grid connection;
- ◆ Laying of scour protection.















Kraken



Supporting Services:

- ◆ 24 hour Pilotage;
- ◆ Ship's Agency;
- ◆ Ship's Chandlery;
- ◆ Electrical/Mechanical services and supplies;
- ◆ Hydraulic services and supplies;
- ◆ Steel Fabrication;
- ◆ Diving and sub-sea engineering;
- ◆ Equipment testing and certification;
- ◆ Mobile Crane and plant hire (Forklifts, Telehandlers, Reach Stackers, Generators, Air Compressors, Temporary lighting);

..... continued over

Supporting Services (..... continued)

- ◆ **Fuel – Oil – Lube supplies;**
- ◆ **Waste Collection and Transfer;**
- ◆ **Security;**
- ◆ **Communication equipment;**
- ◆ **Office Equipment and supplies;**
- ◆ **Laundry;**
- ◆ **Hotel accommodation (for management visits and crew transfers);**
- ◆ **Furnished accommodation for project management personnel;**
- ◆ **Medical/Dental;**
- ◆ **Taxis Services;**
- ◆ **Catering/Hospitality;**
- ◆ **Courier services.**

ROUND 3 requirements:

- Sites are further offshore, some more than 100 nautical miles from the construction port;
- Water depths are as deep as 80m;
- Varying ground conditions at the same site may require different types of foundations;
- Larger capacity turbines (up to 10Mw)?;
- Increased number of offshore sub-stations required;
- Longer cable routes to multiple onshore grid connections

Round 3 Construction Port requirements:

For Rounds 1 & 2 the components including foundations (typically 300–700 tonne monopiles; 150-200 tonne turbines), were delivered either from the loading port directly to the offshore site or loaded on board the installation vessel at a nearby construction port.

For Round 3 however the foundations are expected to exceed 2,500 tonnes and the turbines up to 350 tonnes, therefore the port requirements and equipment will be significantly different and more extensive.

Round 3 Foundations

**There are several different types of foundation
at the conceptual stage**

Floating



- Major owners:**
- Statoil
 - Statkraft
 - Norwind
 - Lyse Produksjon AS

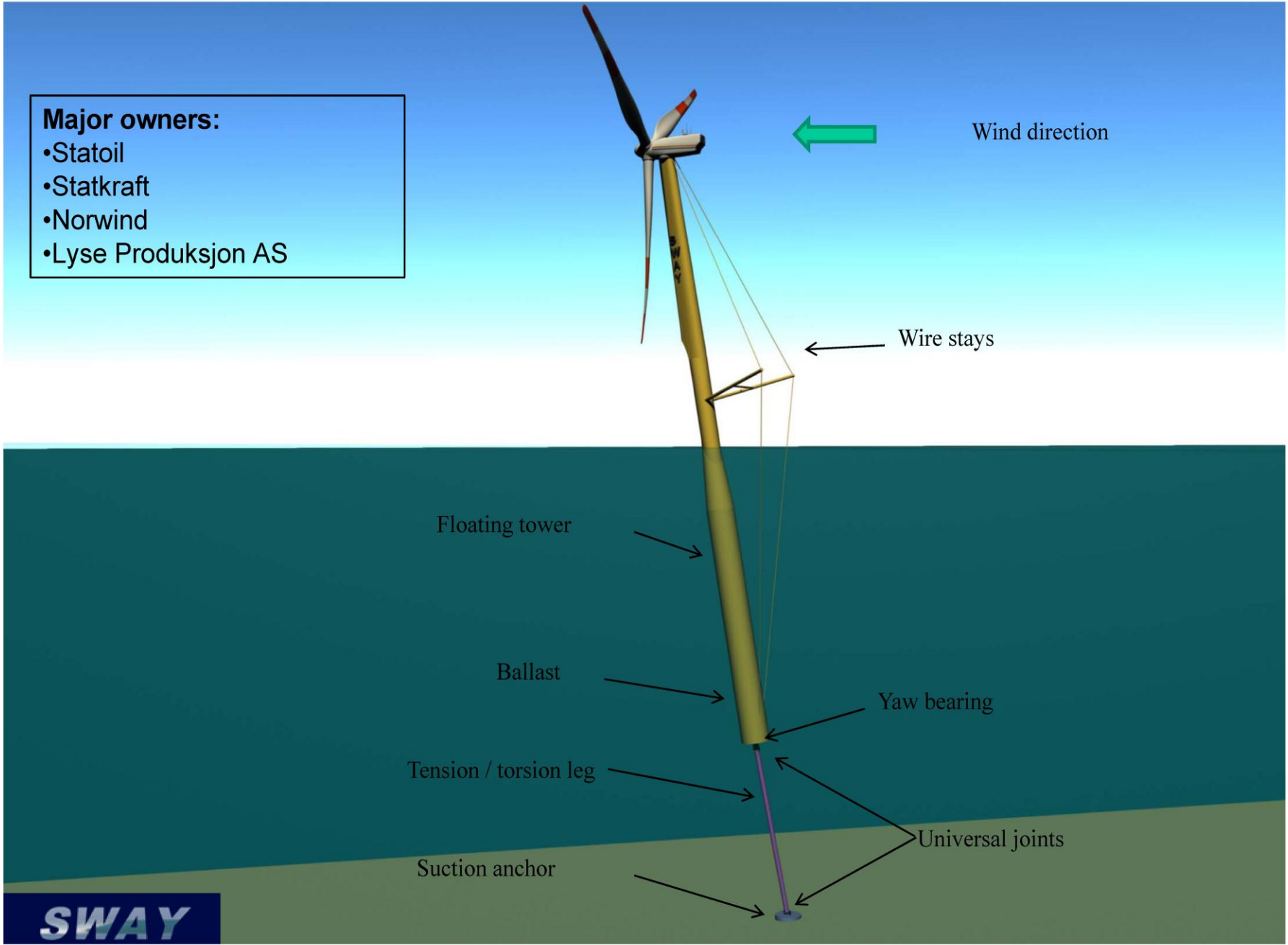

Jacket





RWE npower renewables

Concrete Gravity Base

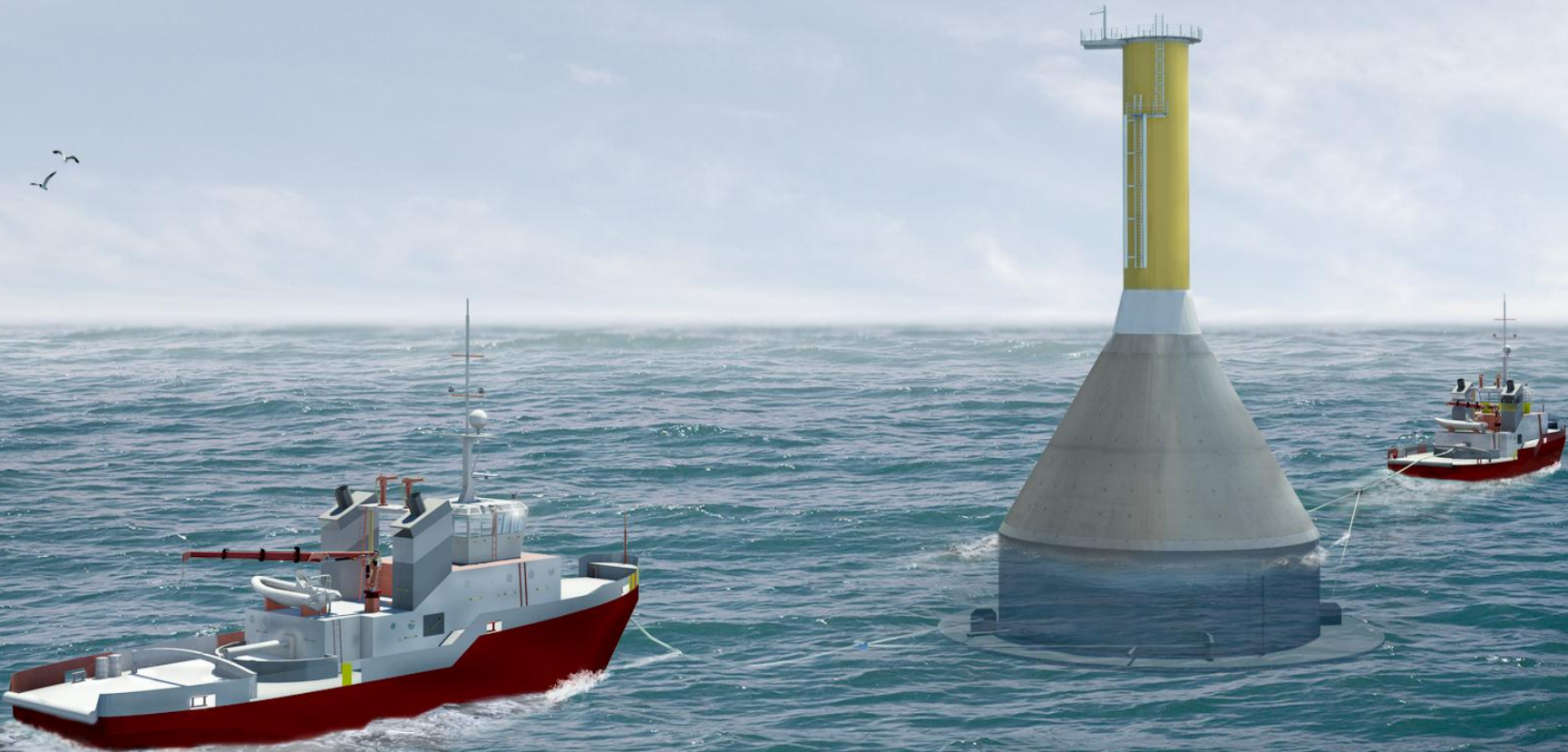

THE GBF FOUNDATION SOLUTION

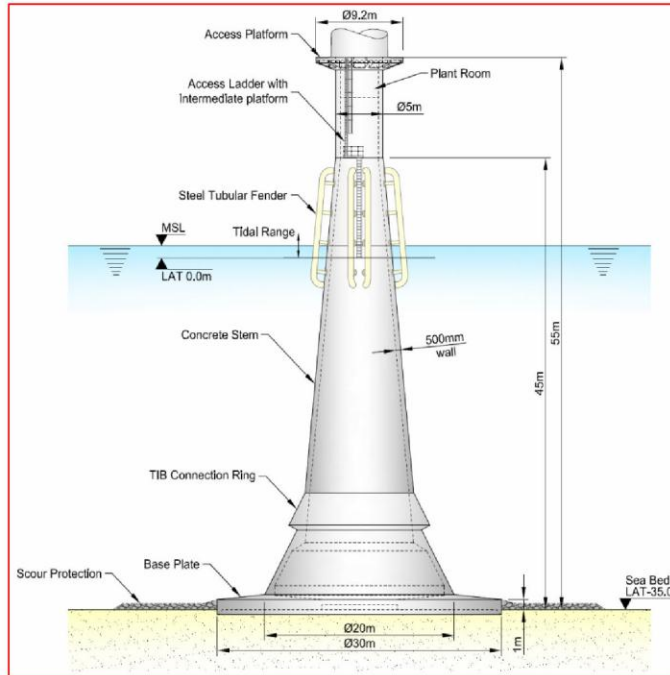

An efficient concrete gravity base structure

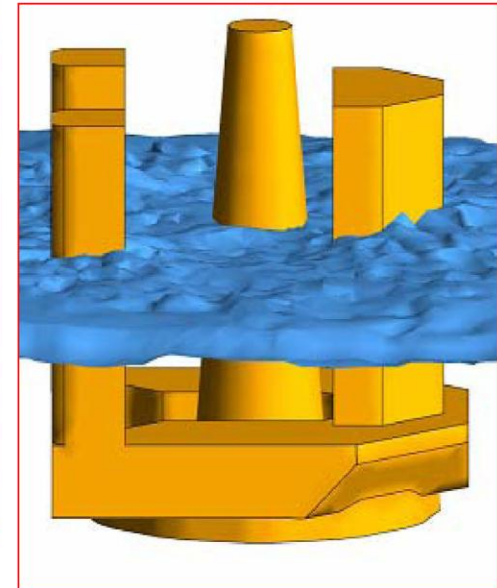

A unique deployment method



STRABAG

The Integrated Construction Base Concept

There are several proposals for an Integrated Construction Base, the benefits of which are said to be:

- On-site construction of foundations reduces transport costs;
- Delivery and storage of turbine components;
- Turbines fully assembled, tested and installed on foundations for delivery offshore as a complete unit;

The Port of Mostyn integrated Construction Base

Proposed I.C.B. to include:

- 600m of quay directly adjacent to the navigational channel including;
- Roll On – Roll Off facilities for turbine delivery;
- Slipway and/or specialised load-out berths for installation vessel;
- 40 hectares (100 acres) of laydown and construction areas;
- Berths for delivery of construction materials by sea;

The Port of Mostyn integrated Construction Base

- Direct road and rail connections for delivery of construction materials by land;
- Marina and Boatyard for service craft;
- Helipad;
- Office/welfare accommodation/car parks.
- In-port support services (Electrical/Hydraulic/Mechanical/Diving/Machine Shop/Steel Fabrication).

Zone 9 – the only Round 3 project in the Irish Sea (due to commence in 2016)

- **Located between Anglesey and the Isle of Man (about 55 sea miles from Mostyn)**
- **About 800 turbines, depending on Mw output (8 times the number of Gwynt-y-Mor)**
- **6 year construction programme.**

Opportunities for North Wales businesses

- **all of the services required for the earlier Rounds 1 & 2 but on a much bigger scale;**
- **4-6 rigs engaged in construction;**
- **each with 40-60 people on board**

If Gravity Base Foundations are chosen, each will require about 2,500 tonnes of concrete:

- ◆ **Sand, cement, aggregates, reinforcing steel;**
- ◆ **Slip form shuttering;**
- ◆ **Batching plants;**
- ◆ **Handling equipment;**
- ◆ **Haulage;**
- ◆ **Scaffolding**

..... continued over

If steel jackets are chosen:

- ◆ **Steel supplies;**
- ◆ **Welding services (mobile welding equipment) welding supplies;**
- ◆ **Coded Welders;**
- ◆ **Industrial painting services and paint supplies**

Projects from 2012-2022

Round 2: Gwynt-y-Mor project to be constructed 2012-2015 and will produce 576Mw of electricity;

Round 3: Zone 9 project due to commence construction 2016-2022 producing 4.2Gw (8 times the capacity of Gwynt-y-Mor:

- Construction on both projects will be followed by 25 years of operation and maintenance;
- As turbine design and efficiency improves, some operators may renew the main turbines;
- De-commissioning.

Port of Mostyn's Role on behalf of the Windfarm Operator

- Provide berths for ships and construction vessels;**
- Stevedoring, Pilotage, Mooring Gangs;**
- Warehousing and Storage Land.**

For the Vessel Owners

- **The purchase of goods and services on behalf of the vessels**
- **Food**
- **Consumables**
- **Laundry**
- **Oils, lubes & grease**
- **Tools**
- **Equipment**
- **Stationary**
- **Hotel accommodation**
- **Travel arrangements**
- **Dental/medical services.**

Acknowledgments & Thanks

- ❖ Principle Power
- ❖ Sway
- ❖ Vattenfall Wind Power Ltd.
- ❖ RWE npower renewables
- ❖ Gravitas Offshore
- ❖ Hochtief (UK) construction Ltd.
- ❖ Gifford UK
- ❖ Vinci Construction UK Ltd.
- ❖ Strabag Offshore
- ❖ Haskoning UK Ltd.
- ❖ Siemens Wind Power

DYLAN J. WILLIAMS BA (Hons), MSc, MA, M.R.T.P.I.
Pennaeth Gwasanaeth Dros dro - Datblygu Economaidd
Acting Head of Service - Economic Development

CYNGOR SIR YNYS MÔN
ISLE OF ANGLESEY COUNTY COUNCIL
Canolfan Fusnes Môn • Anglesey Business Centre
Parc Busnes Bryn Cefni • Bryn Cefni Business Park
LLANGFNI
Ynys Môn • Isle of Anglesey
LL77 7XA

ffôn / tel: (01248) 752431/2435 ffacs / fax: (01248) 752192

Gofynnwch am / Please ask for:
E-bost / Email: ladpl@anglesey.gov.uk
Ein Cyf / Our Ref: DJW/LD/ 812.02
Eich Cyf / Your Ref:

Dyddiad / Date: 28 February 2012

Committee Clerk
Enterprise and Business Committee
National Assembly for Wales
Cardiff Bay
CF99 1NA.

Dear Sir/ Madam,

Re. Inquiry into International Connectivity through Welsh Ports and Airports

The Isle of Anglesey County Council (IACC) welcomes the opportunity to provide comment in the Inquiry into International Connectivity through Welsh Ports and Airports.

As you are aware the Isle of Anglesey County Council is committed to delivering the Energy Island Programme (EIP) which aims to establish the Island as a world renowned centre of excellence for producing, demonstrating and servicing low carbon energy, which in turn will provide a sound base to encourage economic diversification and transition, which will deliver positive benefits over the longer term.

The proposed the Energy Island Enterprise Zones should help Anglesey to capitalise on the planned investment and growth potential of the low carbon energy sector. Due to the facilities and opportunity for development Holyhead Port has a key role to play in securing the Island's economic future, in particular by supporting the offshore wind Round 3 zone and in particular the potential development of a new nuclear power station at Wylfa Head.

Forming part of the E22 Euroroute the Port of Holyhead is one of Britain's most essential ports providing a gateway between the Republic of Ireland, the UK and Continental Europe, and is a major source of direct and indirect employment on Anglesey. The Port is currently primarily used for both passenger and freight ferries, but its extensive harbour and surrounding land provides a number of opportunities for expansion.

The development of the Anglesey Airport has provided significant benefits in reducing the commute to between North and South providing improved business and collaboration opportunities.

The importance of Welsh Ports and Airports cannot be under estimated and have a significant role to play in securing the Country's future economic growth, whilst supporting local economic prosperity. It is therefore essential that the Welsh Government invest vital resources to support and improve local, regional, national and international connectivity.

For your information I also attach the IACC's written evidence to the House of Commons Welsh Affair Committee Ports in Wales enquiry (June 2009) which we believe that this is still relevant.

Against this backdrop please find attached the IACC response to the key issues to be considered by the Enterprise and Business Committee. We hope the comments provided will be of value and would welcome the opportunity to discuss any aspect of our response in greater detail.

Yours sincerely,

Dylan J Williams
Acting Head of Service – Economic Development

cc.

Mr. Arthur Owen – Corporate Director – Planning & Environmental Services

Mrs. Sasha W Davies – Energy Island Programme Director

Mr. Dewi Williams – Head of Service – Highways & Transport

Mr. Dewi Roberts – Principal Transport Officer

Cllr. Tony Sharps (Flintshire Council) – TAITH Chair

Cllr. Dylan Jones – IACC TAITH representative

Cllr. Bryan Owen – IACC Leader/ Transport Portfolio Holder

Mr. Alex Aldridge – IACC Commissioner

Mr. Dave Heggarty – Head of Regeneration – Flintshire County Council

Mr. Jamie Christon – Stena Line Ports Ltd

Mr. David Buck – Manx 2

What role do the Welsh Government and local authorities play in facilitating the development of Welsh ports and airports?

In delivering the Regional Transport Plan, the Regional Transport Consortia aim to progress schemes to improve transport facilities. The roles and activities which the Isle of Anglesey County Council (IACC) undertakes to support and facilitate the development of the Port of Holyhead can be summarised as:

- Enhancing the operational capability of Holyhead Port in order that the facility can be of mutual benefit in delivering the Energy Island Programme, including the potential new nuclear build at Wylfa Head and development of offshore wind Round 3 zone;
- The Strategic Transport Study and Position Statement for Major Developments produced by the IACC in 2011 places a high emphasis on the use of ports to facilitate the construction and operation of major developments;
- Project lead in delivering the EU Interreg funded 'Celtic Wave' project which aims to improve the profile of several Irish Sea Cruise Ports as cruise tourism destination. The IACC are currently developing the second phase of the project and the Welsh Government's on-going support would be invaluable.
- Facilitating the development of cruise facilities within the port with the aim of increasing the region's status within the cruise market.

It is the view of the IACC that the Welsh Government's role in the development of the Port of Holyhead is:

- To create a holistic Port Development Policy/ Strategy for Wales to ensure the economic potential of Ports are maximised;
- To support the delivery of the National Transport Plan for Wales to look at enhancing the international connectivity from Cardiff Airport and to exploit fully the potential of our ports;
- To collaborate to improve the sustainability of freight transport;
- Administer the Freight Facilities Grants which provides significant opportunity to assist with the provision of rail-freight terminals in the region's ports.

Roles and activities which the Isle of Anglesey County Council (IACC) undertakes to support and facilitate the development of the Anglesey Airport can be summarised as:

- To manage the contract for running and managing the terminal building and car park;
- To maintain the ongoing commitment between this the IACC and Welsh Government to facilitate the operation of the Anglesey – Cardiff air link;

It is the view of the IACC that the Welsh Government's role in the development of the Anglesey Airport is:

- To continue to support and subsidise the Cardiff-Valley air link;
- To further develop Cardiff airport and encourage/ promote its utilisation for onward travel by passengers from Valley;
- To continue to support improvement to international connectivity in terms of access to and from business markets throughout the world;
- To ensure that there are a range of facilities in Wales that will reduce the need to travel to airports outside Wales.

To summarise the IACC are committed to maximizing the role of Holyhead as a key UK international gateway and securing improvements to connectivity in terms of internal and external links through Anglesey Airport.

What factors have contributed to the decline in business through Cardiff Airport?

From an IACC perspective the issues which have contributed to the decline of business through Cardiff Airport can be summarised as:

- Inadequate transport links between Cardiff Airport and Cardiff City Centre;
- The facilities at Cardiff Airport may not have kept pace with its nearest located airport (Bristol) reducing its attractiveness to air carriers and passengers.
- The reduction in the range of destinations served by Cardiff through the loss of specific carriers and routes has reduced the competitiveness of Cardiff as an international airport. Having a reduced range of flights will have had a knock on effect for short haul flights that can be used to transfer to longer haul flights;

- The increases in flight taxes particularly on international flights may have reduced overall passenger figures for all airports;
- The growth in stay at home (UK) holidays;

In addition it would be reasonable to assume that the economic downturn has also reduced usage of the Intra-Wales air service. The collapse of Highland Airways in 2010 resulted in a 5 week break with many passengers not having returned to the service.

How effectively does Welsh Government policy, primarily in the areas of transport, economic development, and land use planning policy, support the development of Welsh ports and airports?

At present there is limited synergy and alignment between Welsh Government transport policy, economic development policy, infrastructure priorities and delivery plans.

Although Ports policy is reserved to the UK Government the National Policy Statement for Ports notes that the Welsh Government is responsible for many related functions, including transport and land-use planning. It is therefore essential that any development applications relating to Wales adhere to Welsh Government Policies including the Wales Spatial Plan, the Wales Transport Strategy, the National Transport Plan and Regional Transport Plans.

The effectiveness of synergy and collaboration is clearly highlighted following the Welsh Government announcement that Enterprise Zones were to be developed in Wales, with the IACC, WG and key partners working collaboratively to develop the Energy Island Enterprise Zone (EZ) proposal. The development model of the EZs clearly has the potential to provide the synergy between the policy areas detailed above.

How can the Welsh Government develop economic opportunities, for example from tourism, international trade, freight and, in the case of ports, opportunities including the energy and renewable energy industries? What role do ports and airports, particularly Cardiff Airport, play in the key sectors identified by the Welsh Government?

The Welsh Government's commitment to developing the Energy Island Enterprise Zone is a significant opportunity to capitalise on the planned investment and growth potential of the low carbon energy sector on Anglesey. The EZ designation provides additional levers and builds on the Energy Island Programme, which together will balance and grow the Anglesey economy, make a major contribution to the emerging energy and environment sector plan and Programme for Government.

Holyhead Port has been identified within the draft prospectus as appropriate for EZ development. The deep water port facilities and surrounding premises and development plots provide a number of opportunities to take advantage of the potential investment in the offshore wind Round 3 zone, existing supply chain firms role in offshore renewable market and the proposed new nuclear build at Wylfa Head.

However in order to capitalise on the significant opportunities afforded by delivery of the Energy Island Programme and the Energy Island Enterprise Zone it is essential that the Welsh Government clearly illustrates the development policy, delivery plan, roles and responsibilities.

In addition the recognition of Welsh Ports as a key priority in post 2013 structure fund programmes is essential. The proposed €50bn Connecting Europe facility to improve Europe's transport, energy and digital networks provides significant opportunity to maximise the economic development opportunities associated with the Region's transport infrastructure, including Ports and Airport.

The Europe Connect mechanisms must also be capitalised on fully.

How effective is Welsh transport infrastructure and interconnectivity in supporting the development of Welsh ports and airports?

The IACC believes that interconnectivity is key to supporting the development of Holyhead Port and Anglesey Airport. The following areas require improvement/ further consideration should funding be available:

Holyhead Port

- A link between the end of the A55 (the Western end of the E22 European motorway network linking the ferry route through Holyhead, to Russia, via the Netherlands, Germany, Sweden and Latvia) and the port;
- Capacity issues on Britannia Bridge (this is the only non dual carriageway section of the E22 from its start at Holyhead). The bridge is subject to regular congestion problems at peak hours and at times of the day when ferry traffic reaches this pinch point;
- Replacement of the roundabouts at Llanfairfechan and Penmaenmawr with grade separated junctions. (In addition there are other issues that need addressing in North East Wales particularly in the Queensferry area that would improve the journey times from Holyhead Port to the M56 motorway).
- Whilst rail passenger services to Holyhead are at least hourly, the majority of the journeys would benefit from reduced journey times, achieved through increasing line speeds, and changes to the stopping pattern. Providing additional stopping services would allow longer distance trains to omit calling at smaller stations. The high speed trains used on services to London are capable of speeds of 125mph, but many sections of the North Wales Coast Line are restricted to 75mph, with the fastest sections limited to 90mph. Britannia Bridge is also the only single line section of the route.
- Holyhead Port currently has no facilities for rail freight although until 1991 the port had an intensively used rail freight container terminal. The development of facilities to allow the transfer of freight from road to rail is a key requirement of ensuring Holyhead Port remains competitive and sustainable.

Anglesey Airport

- The road link to Anglesey Airport has seen some improvements over the past two years, which has resulted in the route being more suitable for the buses used on the service which operate via the airport. Further improvements are planned subject to availability of Regional Transport Plan funding, which would result in the link to signed route from the A55 to the airport being changed from junction 4 to junction 3, providing a route free of obstruction from parked cars to Anglesey Airport.

The IACC understands that there are plans to develop a Wales Infrastructure Investment Plan to identify developments that are critical for port/ airport development and request that Local Authorities are fully involved in the plans development from the onset.

Given that ports and airports policy is a reserved matter, how effectively does the Welsh Government engage with the UK Government in the interests of Wales?

The Welsh Government has a vital role in promoting the interest of Wales whilst engaging with the UK Government, but due to the non-devolved status of Ports policy the IACC is concerned that National Ports policy is being focused on England. As a result there have been examples over recent years where the reluctance on behalf of both parties to accept responsibility has resulted in the loss of a rail service. The most recent example concerns the loss of a night boat train from Holyhead which had initially been part of a franchise which predated the current all Wales Rail Franchise. The journey was not included in the all Wales Rail Franchise as it was being provided by the operator of the West Coast Trains Franchise on behalf of Virgin Trains, however, due to other changes to the Virgin Trains services, the company no longer provided the night boat train and was not contractually bound to provide it as it was not included within the franchise. As a result of this, neither the Welsh Assembly Government at the time or the DfT would accept any liability for the loss of this service as a result of a lack of foresight in ensuring the journey was part of one of the franchises.

What impact do EU State Aid regulations have on the ability of the Welsh Government to provide support, and what opportunities are presented by EU ports and airports policy to support development in Wales?

There is currently a lack of clarity as to whether or how EU State Aid regulations impact on ports and airports investment, and has served to complicate/ constrain some port infrastructure improvement plans.

Given that Holyhead Port as a gateway port between Continental Europe, the UK and the Republic of Ireland, is located on the two EU TEN-T priority axes (13 and 26), this should result in opportunities for state aid to be drawn down for improving the infrastructure of the corridor and the port. Ensuring that all member states have

equal access to fund on the same basis is imperative, if we are to ensure that Wales maximises the opportunity for state aid.

The road and rail corridors linking Holyhead to the European motorway network and to the West Coast Main Railway Line would be eligible for TEN-T funding, but the relatively low intervention rate would require significant match funding to be sought. Given that the most likely source of match funding opportunities would be through EU Convergence funding, and that one EU grant could not be used to match another EU grant, the securing of sufficient funds to carry out major projects is difficult. To secure EU funding, it is vital for the Welsh Government to allocate sufficient internal funding to transport infrastructure projects to allow EU funding to be drawn down to enable strategic projects to be delivered. The IACC is eager to continue to collaborate with the Welsh Government on the development of a strong proposal/ outcome driven business case to secure Europe Connect funding to improve the A55/ TEN-T transport corridor across North Wales.

The current State Aid regulations covering the operation of Public Service Obligation (PSO) air routes do enable the Anglesey – Cardiff service to be provided, which is welcomed. However, expanding routes from Anglesey to locations outside Wales without State Aid is difficult and carriers are unlikely to initiate services as a purely commercial venture. Making available State Aid to assist in the market testing of new routes would be a welcome addition to the current funding opportunities.

Ports in Wales - Written evidence from the Isle of Anglesey County Council

EXECUTIVE SUMMARY

Anglesey faces serious economic challenges, and local deprivation is concentrated around its port areas. Holyhead port is a critical generator of jobs and income for the local economy. Government should support projects which will safeguard this, and more effectively exploit and develop the port's potential and contribution to the local economy. Key projects in this respect include the proposed cruise ship terminal, the planned direct road link between the port and A55, and the need for a lorry park facility. The extensive harbour has many uses with scope for more, and the waterfront area is subject to ambitious development plans.

1. INTRODUCTION

1.1 Anglesey County Council welcomes the Welsh Affairs Committee's decision to hold an inquiry into the issue of Ports in Wales. Anglesey has a number of ports and harbours located around our coastline, but most of our evidence inevitably relates to the port of Holyhead due to its size and status.

2. ECONOMIC CONTEXT

2.1 Anglesey faces a number of significant economic challenges, and now has the highest unemployment rate of any county in North Wales. The Island has seen the erosion of its industrial base in recent years. This will be added to by the closure of Eaton Electrical in late 2009, and a decision on the future of Anglesey Aluminium is expected shortly, both in Holyhead.

2.2 There is generally a correlation between economic prosperity and proximity to the mainland. The Island's socio-economic problems are particularly severe in the wards surrounding the port of Holyhead, and also that of Amlwch Port. Of the 10 LSOA's on Anglesey with the highest unemployment rates, seven are in Holyhead, and one is in Amlwch Port. These areas account for five of Anglesey's six Communities First wards.

2.3 It is important that government encourages and supports plans to more effectively develop the economic potential of ports, especially in areas of high socio-economic need such as Anglesey.

3. PORTS AND HARBOURS OF ANGLESEY

3.1 *Holyhead*

Holyhead is a major strategic port of great importance as a link between the UK and Irish Republic, and it is dealt with in detail in the remainder of this report.

3.2 *Amlwch*

The narrow harbour of Amlwch was originally developed to serve the copper industry. During the late 1970s it was improved to serve the needs of oil importation from tankers, for transfer to the nearby Rhosgoch tank farm, and from there via pipeline to Stanlow in Cheshire, but this operation was short-lived. The nearby Great Lakes (previously Octel) bromine works was the town's major employer—it has now closed, but there are plans by gas company Canatxx to use it to land and refine Irish Sea gas. The main users of Amlwch harbour today are private leisure craft, boat excursion operators, and commercial fishing boats. The harbour also provides a base for pilot vessels of the Mersey Docks and Harbour Company, assisting large ships travelling to Liverpool. There are plans to develop the historic harbour area as a tourist destination. Anglesey County Council is the local harbour authority.

3.3 *Beaumaris*

Although historically a port, Beaumaris now lacks a sheltered harbour. Current facilities include a leisure pier, moorings, and a boatyard, which are used by private leisure craft and by tourist or fishing boat excursion operators. A proposal for a new marina has recently been thwarted due to opposition by mussel fishermen and related agencies, and the decision has thrown in doubt the legality of some 400 Menai Straits moorings.

3.4 *Menai Bridge*

The modern pontoon pier is used by research vessels of the nearby University of Wales Marine Science department, and by some leisure and small commercial craft. As in Beaumaris, the pier and moorings are owned and managed by the County Council.

3.5 *Cemaes*

There is a small sheltered harbour in Cemaes which was built to serve the needs of local past industry. It is now used by leisure craft and a small number of fishing boats and charter boat operators. The harbour is owned and managed by local trustees.

3.6 *Other Harbours*

There are various small-scale jetties, slipways, and other maritime facilities around the Anglesey coast, mostly related to leisure craft usage.

4. HOLYHEAD PORT

4.1 *Holyhead's Harbours*

Holyhead's use as a harbour dates back to Roman times. Its development as a major port was linked to the building of the A5, the extension of the railway from Chester, and the Admiralty's decision to create a large harbour of refuge. Holyhead's role as a strategic transport node has been reinforced by the building of the A55 dual carriageway from Chester, part of a designated Euroroute (E22). Recent port infrastructure developments have been focussed on the East Dock side of the Inner Harbour, and on Salt Island from where deeper water can be reached.

4.2 *Port Employment*

Holyhead Port is one of Anglesey's major employers, providing approximately 900 jobs. Stena accounts for well over half of these, with the remainder being in Irish Ferries, port service companies, transport and other businesses, together with some public sector staff in the port police and customs. Stena has sited some of its UK-wide service and support operations locally. Given other job losses, it is essential that government supports port employment.

4.3 *Ferry Services*

Holyhead is the busiest ferry port in Wales, handling about 2.3 million passenger movements each year. There are two ferry companies operating a total of five ferry vessels, and both have invested heavily in developing new berths and port related facilities. The ferries carry foot passengers, cars, coaches, and lorries, varying by vessel. Foot passenger numbers has declined in recent years, but the number of lorries using the ferries has increased very significantly.

4.4 *Sea Freight*

The bulk of sea freight activity via Holyhead involves lorries using the ferries to transport goods to and from Ireland. (There used to be a sea container facility on the East Dock, but the company withdrew and the site was later redeveloped for ferry uses). Other significant freight operations involve the import of fuel to the port and of aluminium ore to Anglesey Aluminium, and the export of aluminium ingots. The ore is landed on a purpose-built jetty, and is transported via underground conveyer to the smelter (the possibility of also using this to import wood chip for a power station is now being considered). There are other occasional freight uses, e.g. the export of stone for marine works. It is hoped that storage and distribution facilities and related jobs can be attracted to the new Parc Cybi business park.

4.5 Port—A55 Link

4.5.1 The growth in ferry traffic, especially lorry numbers, has led to stresses on the transport network. Problems occur at the Britannia Bridge, and in some other locations along the North Wales coast. A particular problem for Holyhead is the "missing link" between the port and the A55 dual carriageway. The access to and from the port for road traffic needs to be improved to avoid conflict with local traffic, and to reduce congestion, especially for traffic exiting the port.

4.5.2 A scheme has been prepared to address this by creating new direct road link between the port and A55 Junction 1. This will require the relocation of the existing railway depot from near the town centre, and it is proposed to relocate this to land adjacent to Anglesey Aluminium. With support and funding from WAG, Anglesey County Council have been working for several years to plan and design up this project, which now has a cost of about £20 million. A bid for EU Convergence funding has been made, and it is vital that funding is provided to allow the scheme to proceed.

4.6 Lorry Park

Due to the volume of freight traffic using the A55, there is a need for a suitable truck stop/service area for lorries. Drivers are now forced to use normal roadside lay-bys to stop and rest to achieve their mandatory breaks, which have resulted in environmental and other problems in those locations as there are no facilities.

A lorry park would address this problem and could generate local economic benefits.

4.7 Environmental Impact

There are inevitably some localised environmental impacts due to port operations and traffic. The London Road ward has the worst scoring on Anglesey in terms of the WIMD 2008 health indicator. It is expected that pollution levels in local residential areas will be reduced if the rail depot is relocated, and if lorries can access the A55 directly without having to queue slowly over Black Bridge.

4.8 Port and Rail

About 0.5 million people use Holyhead station each year, most being ferry users. Ferry and train times are reasonably well timed, but the locality benefits from some delay. The Town Council operates a left luggage facility to encourage ferry/rail users to visit the town rather than wait in the terminal. The railway station has seen some limited improvement works, but is clearly in need of a significant physical upgrade, including updated signage and information for passengers.

4.9 Rail Freight

There are currently no rail freight facilities at the port of Holyhead. The North Wales Rail Strategy Study includes the option of a rail freight terminal at Holyhead, which should reduce the large number of heavy lorries that now operate along the A55. The North Wales railway line is not

currently used by container traffic, and there are gauging and terminal issues to overcome. A rail gauge upgrade is a possible long-term option.

4.10 Cruise Ships

4.10.1 About 5-10 cruise ships have been calling into Holyhead each year, most carrying a few hundred passengers, but there have been several calls by larger ships with around 2,000 passengers. Most cruise passengers tend to go on day or half-day coach excursions, and the cruise ship companies receive much of their income from these.

4.10.2 Typically 25% of passengers from large ships will not go on coach excursions and will walk around the town or visit other places by taxi. Many crew members will also come ashore and spend in local shops. The County Council has arranged events in the town centre on large cruise ship call days. Related initiatives have included customer care courses for taxi drivers, training local "green badge" tourist guides, and arranging short local excursions.

4.10.3 The Cruise Wales partnership aims to develop Wales' potential as a cruise destination. Economic studies have been undertaken to measure the economic impact of cruise calls and predict how this is likely to increase in the future. Anglesey County Council is an active member, and will lead the EU Interreg funded "Celtic Wave" joint marketing project for several Irish Sea cruise ports.

4.10.4 Smaller cruise ships berth alongside in the Inner Harbour, but larger cruise ships must anchor outside the port and transport their passengers ashore via small tenders. This is very time consuming and risky. Several large cruise ships have cancelled the landing of passengers using tenders due to conditions on the day being unsuitable. Most cruise lines have now decided to avoid tendering in. The development of an alongside cruise berth is therefore essential to ensure that Holyhead attracts cruise ships in the future, and we are most anxious that this project receives full government support.

4.11 Marine Leisure

The 24-hour outer harbour is well used for marine leisure activities, and there is space and potential for further usage. The local sailing club has a large membership and manages yacht moorings. A private yachting marina has been established which now has a blue flag and about 200 berths, together with an onshore development of commercial units and apartments.

4.12 Tourism

The port makes a significant contribution to tourism in Wales and Ireland. Efforts have been made to increase the level of ferry passenger spend on Anglesey by providing visitor information on the HSS ferry, in A55 lay-bys, and at the ferry terminal, and further marketing initiatives are planned. Holyhead benefits from spends by tourists who are en-route to or from Ireland, and local guest houses rely on ferry users for much of their business. A budget hotel has recently been built, and there is further hotel interest.

4.13 Local Spend by Ferry Users

Ferry users generate a significant level of spend in Anglesey service sector businesses in Holyhead town centre, Holyhead retail park, and other places along or near the A55. The relocation of the port access from the west to the east side of the harbour during the early 1990s adversely impacted on spend in the town centre, and the planned new port access road link scheme on the west side should see many more car and coach-based ferry users stopping and spending in the town.

4.14 Ferry Timings

Ferry frequencies and timings have a significant impact on how many ferry passengers visit the town and how much they spend. Timings are currently not as favourable as they used to be for return day trips between Wales and Ireland. Ferry delays or cancellations can result in a significant influx of passengers into the town.

4.15 Port Heritage

The port includes a large number of historic buildings and structures, many of which are listed as being of historic interest, and a study has been undertaken in conjunction with Cadw. The care of these buildings and structures largely fall on Stena Ports Ltd as port authority. An excellent Maritime Museum is operated by local volunteers in a building leased from Stena, and there are plans for a large expansion to show more of the many artifacts.

4.16 Other Port and Harbour Users

There are very many other users of the port and harbour. These include the RNLI, RAF, Customs, Navy, visiting ships, survey vessels, Sea Scouts, small boating associations, leisure divers, outdoor pursuits operators, among others.

4.17 Holyhead Breakwater

The 1.5 mile long breakwater is a dramatic historic structure which forms the large Outer Harbour, dating back to the early 1800s. The structure is now in need of a major strengthening and restoration scheme. Without these works, the breakwater is in danger of partial collapse. It is hoped that the scheme will also provide for leisure and amenity use of the structure.

4.18 Port and Regeneration

Recent urban regeneration works by the County Council have targeted run-down areas facing the port, and further works are planned. These schemes will integrate with the planned Port Access Road scheme. The recently built Celtic Gateway bridge provides an easy and DDA compliant link between the town centre and foot passenger ferry terminal/railway station, and is also well used by Morawelon area residents. Stena is an active partner in the local regeneration partnership and related initiatives.

4.19 Waterfront Potential

Holyhead's extensive waterfront has been recognised as a key asset for the future regeneration of the town. Port owner Stena has formed a joint venture property development company with London based developers Conygar, and plans for an ambitious mixed-use development for part of the Outer Harbour waterfront are in preparation.

4.20 Offshore Developments

Holyhead is well sited to be a base for servicing offshore developments, and large drilling rigs are sometimes seen in the harbour. Further windfarms are expected in the Irish Sea, together with marine turbines. There are currently constraints in terms of uses that would require very large areas of portside standage.

4.21 Marine Industry

The closure of the Marine Yard in the 1980s was a severe blow, but its tradition continues on a smaller scale. Holyhead Boatyard employs about 60, involved in specialist boatbuilding and repairs, but also in many shipping and overseas activities. There are also many other smaller marine

businesses in and around the harbour, and this sector clearly deserves to be encouraged and assisted to grow.

4.22 Fishing Industry

Holyhead is North Wales' most important commercial fishing port. It is a base for small inshore vessels, but also sees calls by larger trawlers. Almost all fish landings (c£3 million per annum by value) are transported direct for sale outside Wales. The DEFRA Fisheries office for North/Mid Wales and the North Wales Fishermen's Association are both based in Holyhead. There are several facilities for fishing boats, including a Council managed Fish Dock, and EU fisheries funding is available for related works.

4.23 Port Authority

The statutory port authority is Stena Ports Ltd, a port management company which is part of the international Stena group. Although a private company, the functions of Stena Ports Ltd reflect those of a public sector authority in many respects. The port authority's status as a privately owned company has constrained the availability of public funding to some important projects due to funders concerns and uncertainty about EU state aid regulations.

June 2009